

Unità Aggregata / Aggregate Unit : **Fast Line VERTICAL BORE 45/9.5**
Codice / Code : **FL.VBORE.00/C45.63F - H1**

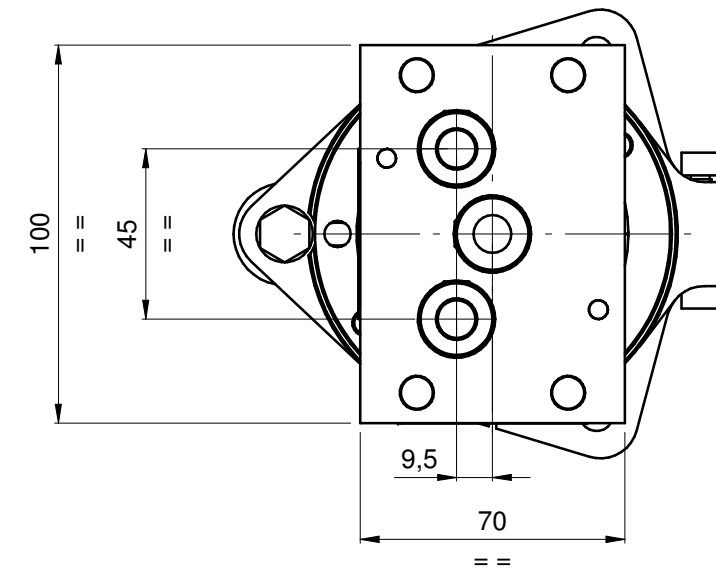

DETTAGLIO Z

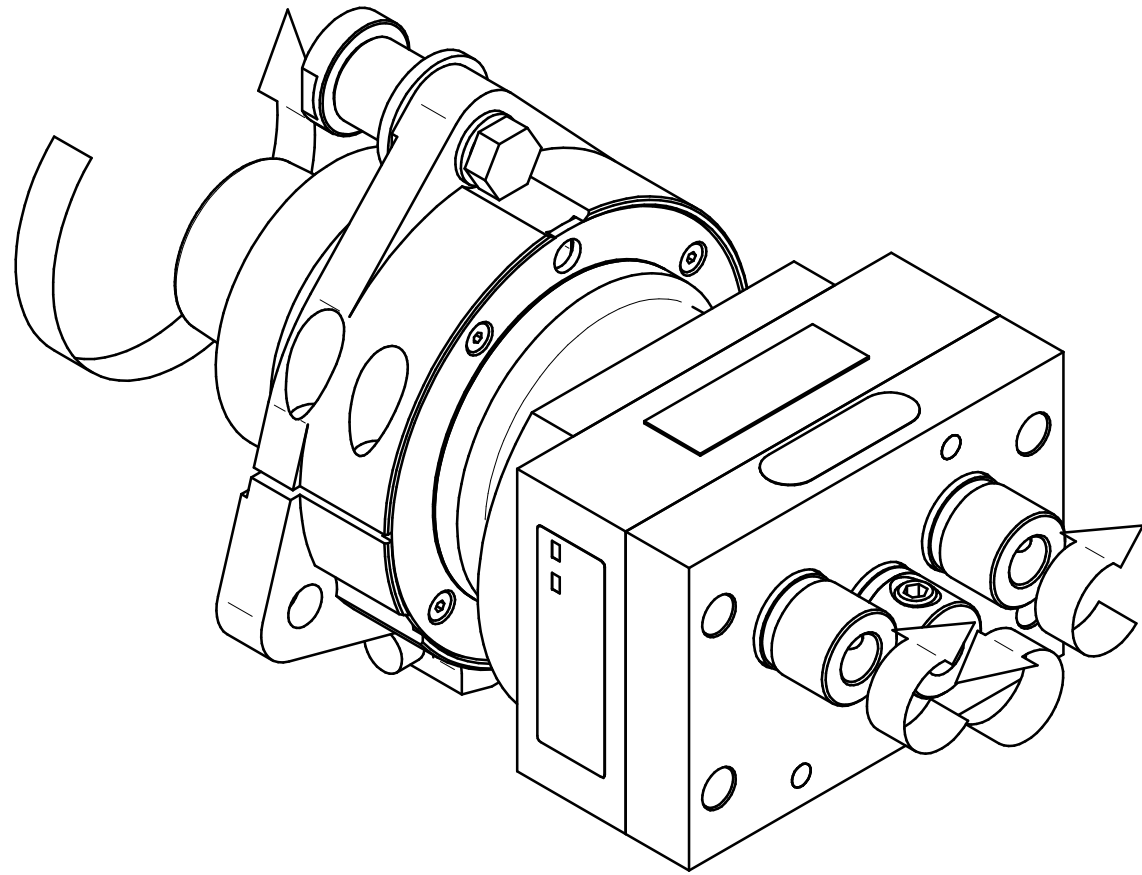
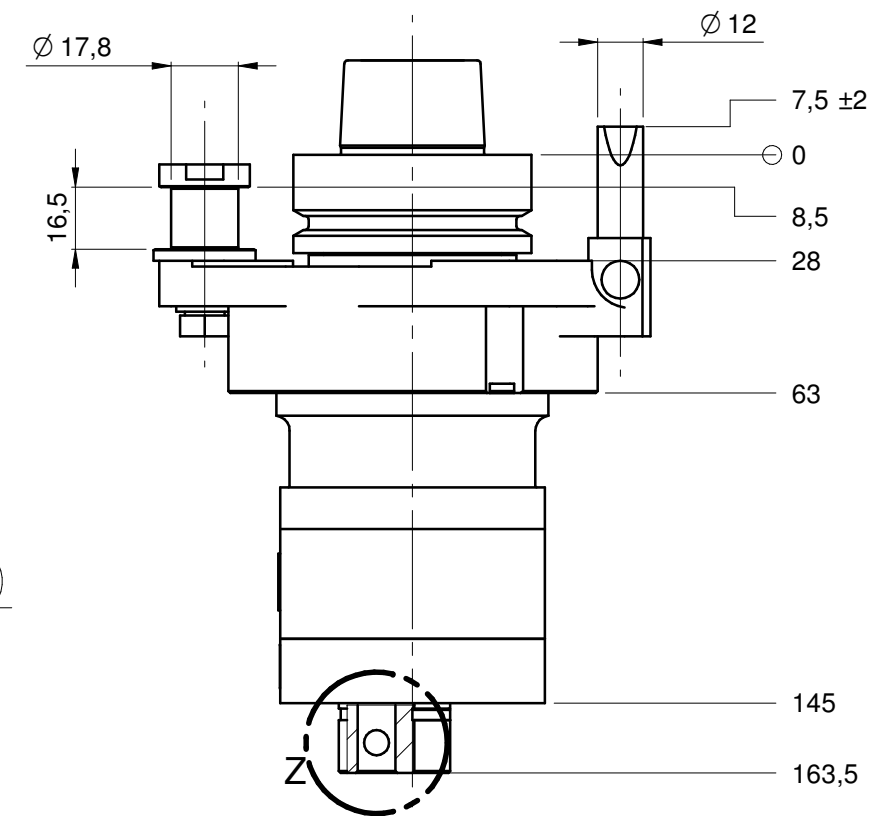
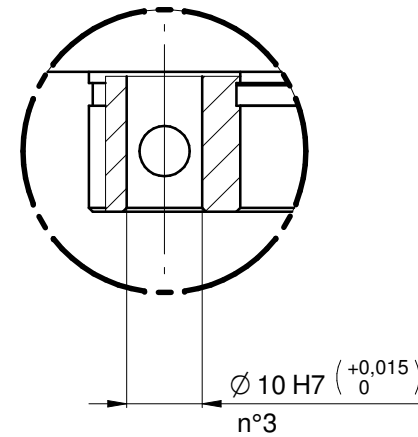

Specifiche tecniche / Technical specifications

Attacco elettromandrino - Spindle coupling	HSK 63F
Max velocità rotazione elettromandrino - Max electrospindle rotation speed	8000 RPM MAX.*
Senso rotazione mandrini - Spindles rotation direction	Vedi schema - Check layout
Possibilità inversione rotazione mandrino - Possibility to change electrospindle direction	SI - YES
Rapporto di trasmissione - Gear ratio	1:1
Attacco punte - Tools coupling	$\varnothing 10\text{ H7 } (0/+0.015)\text{ mm}$
Max diametro punte - Max bit diameter	$\varnothing 10\text{ mm}$
Max lunghezza punte foratura - Max boring bits length	70 mm
Lubrificazione - Lubrication	Kluber Isoflex NBU 15
Connessione asse C - C axis connection type	HIT1
Orientamento angolare - Aggregate rotation	0-360° continuo - continuous
Max temperatura di lavoro - Max working temperature	75°C / 167F
Max coppia in ingresso - Max torque input	10 Nm
Peso - Weight	4 kg
* VEDERE MANUALE/see user manual	

